

MINOLTA

E INSTRUCTION MANUAL

MAXXUM[®]

8000i

IMPORTANT INFORMATION

The Minolta Maxxum 8000i camera is designed to offer innovative functions and performance through the combination of camera body, Maxxum AF lenses, Maxxum Flash units, and other accessories distributed by Minolta. We thus caution users that the attachment or use of incompatible lenses, flashes and accessories may result in unsatisfactory performance or damage to the Minolta Maxxum 8000i camera. To obtain optimum performance throughout the life of your Minolta Maxxum 8000i camera, we recommend that you use only lenses, flashes and other accessories distributed or licensed by Minolta for the Maxxum 8000i.

NAMES OF PARTS

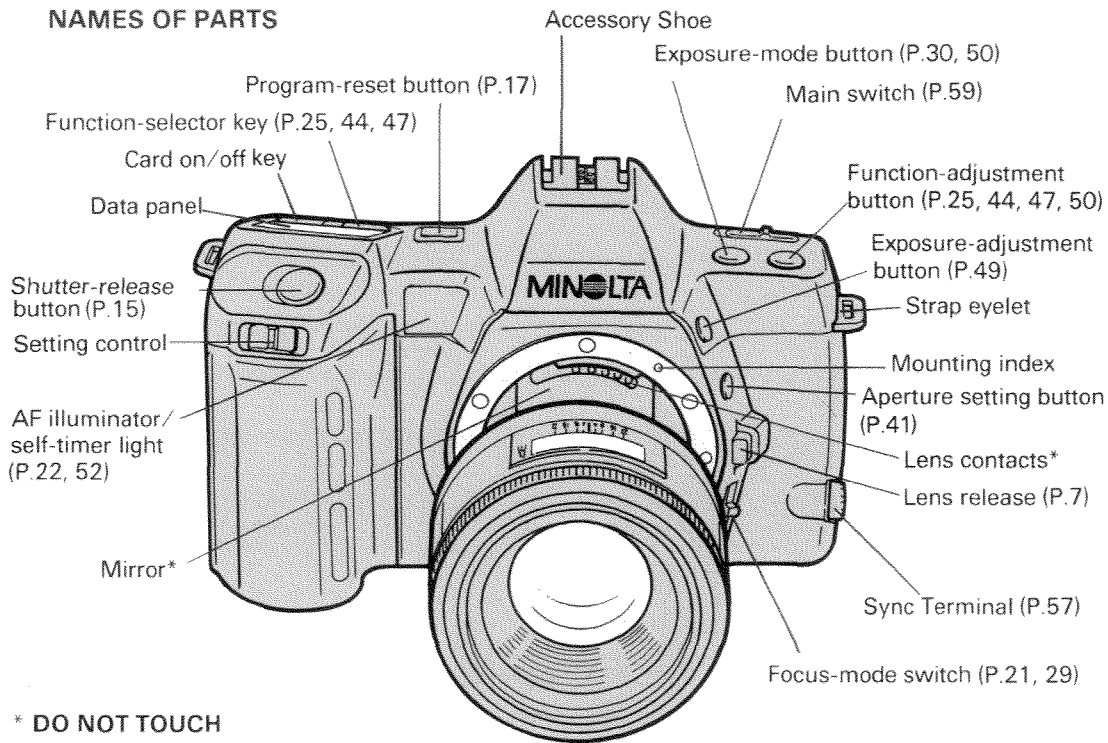

* DO NOT TOUCH

For information on specific parts, refer to the page numbers shown in parentheses.

Thank you for purchasing this camera. Its design is based on state-of-the-art AF SLR technology, and we hope that it will provide you with many years of satisfying results.

Pressing the camera's program-reset button readies it for completely automatic operation. Beyond this, Maxxum 8000i allows for customization of six primary functions: focus mode, autofocus area, exposure mode, metering mode, exposure adjustment, and film-advance mode. A single switch is used for changing the focus mode, while the other five functions are selected using the camera's setting control in combination with the appropriate button. At any time in the course of operation, all settings can be returned to their standard positions by pressing the camera's program-reset button; in addition, the focus mode is reset to AF each time the camera is switched on.

Please take the time to read through this manual and learn about the 8000i's various features, and then keep it handy for future reference; doing so will allow you to take full advantage of your new camera, right from the start.

TABLE OF CONTENTS

Data Panel and Viewfinder Displays	2	P: Program Mode	32
Summary of Operation	4	Program Shift	33
GETTING STARTED		A: Aperture-Priority Mode	35
1. Preparing the Camera		S: Shutter-Priority Mode	38
Attaching and Removing the Lens	6	M: Manual Mode	40
Power	8	5. Metering	
Battery Installation	8	Basic Information	42
Battery-Condition Indicators	9	Mode Selection	44
Film	10	Multi-Pattern and Centerweighted-	
Film Loading	10	Average Metering	44
Automatic Film-Speed Setting	12	Spot Metering	45
Setting the Film Speed Manually	13	6. Film Advance	
2. Basic Operation		7. Exposure Options	
Holding the Camera	14	Exposure Adjustment	48
Shutter-Release Button	15	Multiple Exposure	50
Taking a Picture	16	Self-Timer	52
Program Reset	17	Long Exposures	54
Film Rewind	18	Flash Photography	56
Automatic Film Rewind	18	8. Additional Information	
Manual Start of Film Rewind	19	Main Switch	59
OPERATION IN DETAIL		Cold-Weather Operation	59
3. Focus		Battery Performance	59
Basic Information and Mode Selection	21	Attaching the Neckstrap and Eyepiece	
Autofocus	21	Cap	60
Operation and Viewfinder Focus		9. Troubleshooting	
Signals	21	Accessories	
Focus-Area Selection	24	Appendix	
Focus Hold	26	Operation Chart	78
Special Focusing Situations	28	Viewfinder and Data Panel Exposure	
Manual Focus	29	Warnings	79
4. Exposure		Technical Details	
Basic Information and Mode Selection	30	Care and Storage	

DATA PANEL

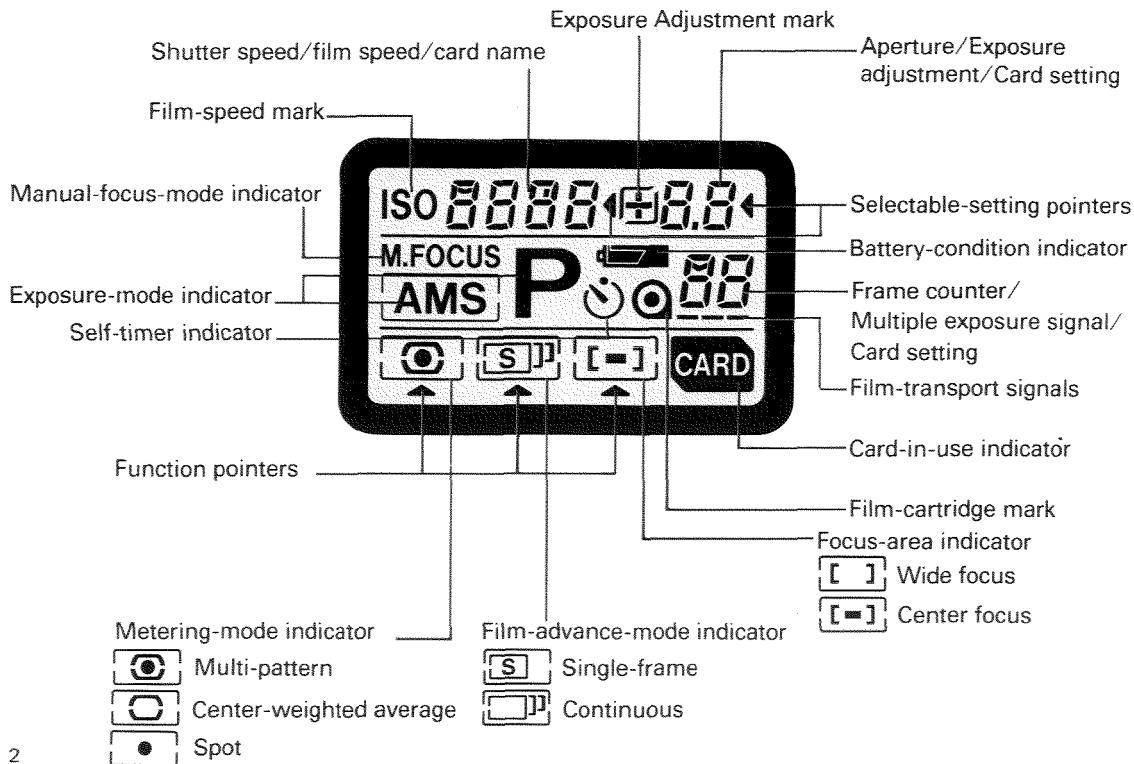

VIEWFINDER

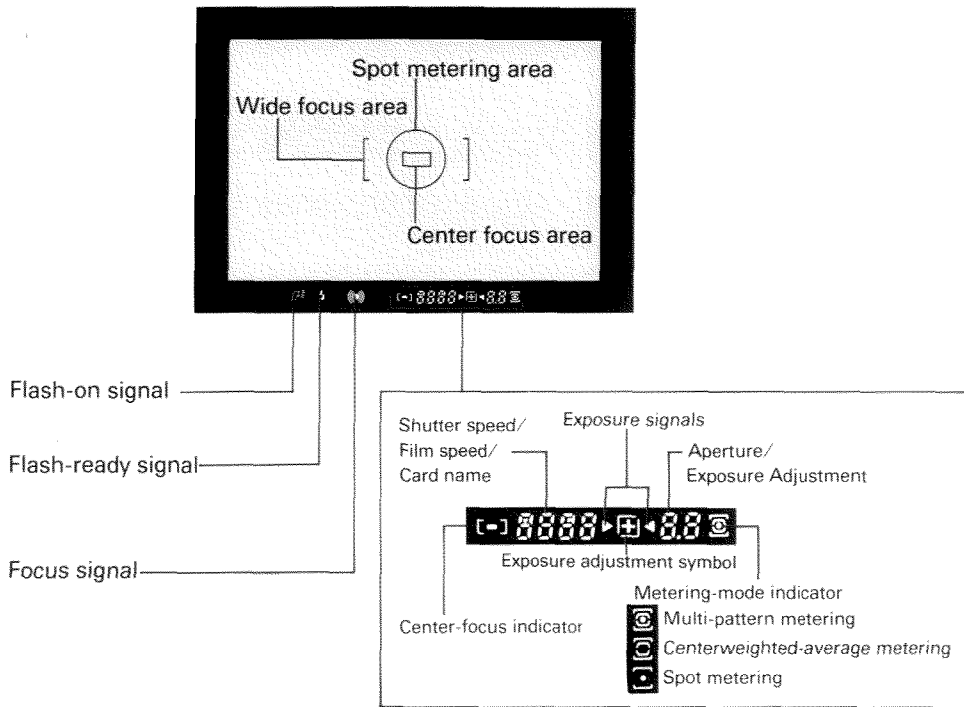

SUMMARY OF OPERATION

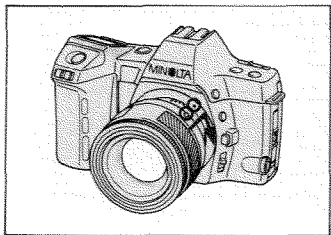

1. Attach the lens (p.6).

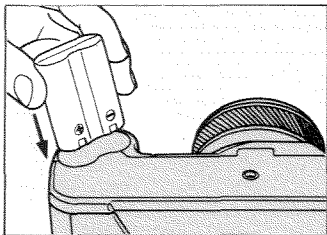

2. Insert the battery (p.8).

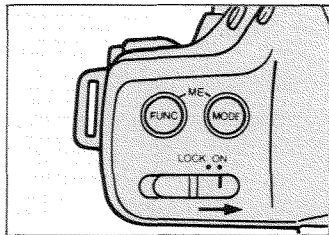

3. Move the main switch to **ON**
(p.59).

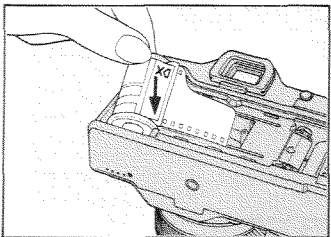

4. Load film (p.10).



5. Press the shutter-release button
partway down to focus (p.16).

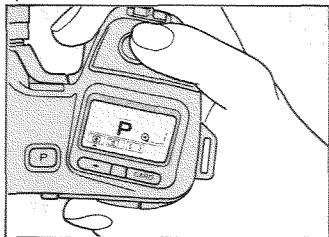

6. Press the shutter-release button
all-the-way down to take the
picture (p.17).

GETTING STARTED

Preparing the Camera
Basic Operation



1. PREPARING THE CAMERA

ATTACHING AND REMOVING THE LENS

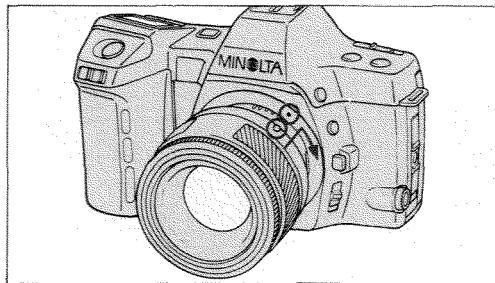
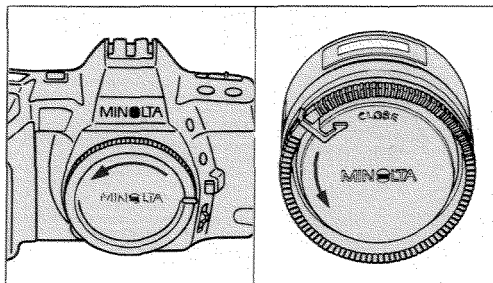

To attach:

1. Remove the body and rear lens caps, as shown.

2. Align the red bead on lens barrel with the red dot on camera's lens mount. Insert the lens bayonet into the mount and turn the lens clockwise until it locks in place with a click.

When attaching or removing lenses, be careful not to touch anything inside the camera, especially the lens contacts or mirror. To protect the lens contacts and elements, attach the lens caps whenever the lens is not in use.

If lens is not attached properly, -- appears in the data panel's aperture display when camera is switched on.

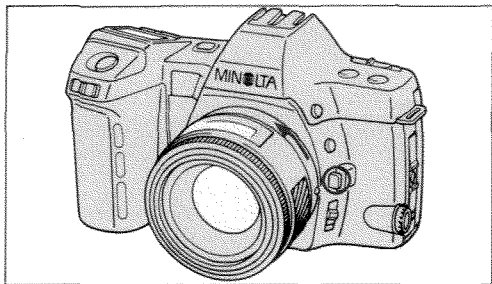

To remove:

1. While pressing the lens release, turn the lens counterclockwise as far as it will go, then lift lens out of mount.
2. Attach another lens or the body cap to prevent dust from entering the camera.

Care of Glass Surfaces

- Never touch lens elements or the camera's eyepiece with your fingers. If the lens becomes dirty, clean it gently with a lens brush. Only if necessary, moisten a sheet of lens tissue with one drop of lens-cleaning fluid and, starting at the center and using a circular motion, lightly wipe the surface of the lens.
- Never lift the mirror or touch its surface, since this may impair its alignment. Dust specks on the mirror's surface will not effect exposure or picture quality. If dust on the mirror is distracting, the camera can be cleaned at an authorized Minolta service facility.

POWER

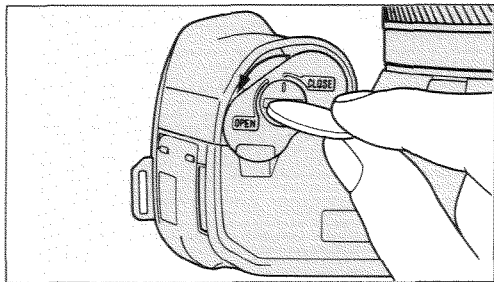

This camera uses a 6-volt 2CR5 lithium battery that supplies power for all camera operations.

Battery Installation

1. With the main switch at **LOCK**, use a coin or similar object to turn the battery-cover lock to the **OPEN** position. Remove the battery cover.

If necessary, wipe the battery terminals with a dry cloth to ensure proper contact.

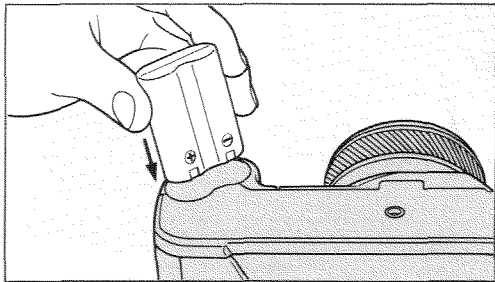





2. Insert the battery according to the marks in the battery compartment.
3. Replace the battery cover and turn the battery-cover lock to the **CLOSE** position.

CAUTION

- Do not disassemble or short-circuit the battery or subject it to high temperatures or fire. The battery may explode or cause burns.
- Read and follow all warnings and instructions supplied by the battery manufacturer.
- Keep batteries away from young children.

Battery-condition indicators

Each time you slide the main switch from **LOCK** to **ON**, the camera automatically checks the battery and displays a condition indicator in the data panel:

-  _____ Full-battery symbol appears for five seconds: Power is sufficient for camera operation.
-  _____ Low-battery symbol appears for five seconds: Power is sufficient but getting low— **keep a fresh battery handy**.
-  _____ Low-battery symbol blinks: Camera can be operated, but the **battery will need to be changed soon**.
-  _____ Blinking low-battery symbol alone, or no display at all appears, and the shutter cannot be released: Power is too low for normal operation— **replace the battery**.

In cases ③ and ④, the battery-condition indicator appears whenever the shutter-release button is pressed down. If no display appears when the main switch is set to **ON**, double-check that the battery is inserted correctly before inserting a fresh one.

FILM

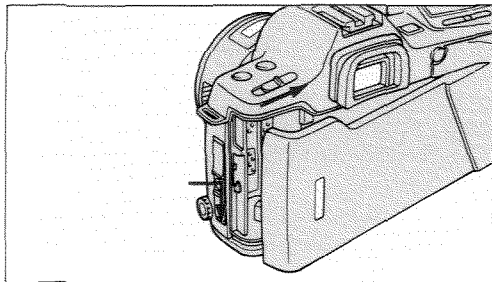

Film Loading

1. Slide the main switch to **ON**.
2. Open the back cover by sliding the back-cover release downward. (When loading film for the first time, remove and discard the protective plastic cover that is attached to the pressure plate.)

- Before opening the back cover, check that **0** is displayed in the frame counter; if not, film is already loaded and the camera should not be opened. The type of film loaded can be verified by checking the film window. (For instructions to rewind a partially exposed roll of film, refer to pg. 19).

- Always load film in subdued light, or at least shaded from direct sunlight.

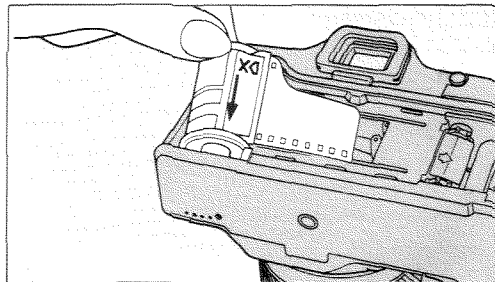

3. Place the film cartridge into the film chamber, as shown.

RIGHT

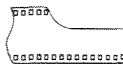

WRONG

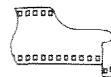

Make sure the tip of the film is correctly shaped. Otherwise, the film may not wind properly.

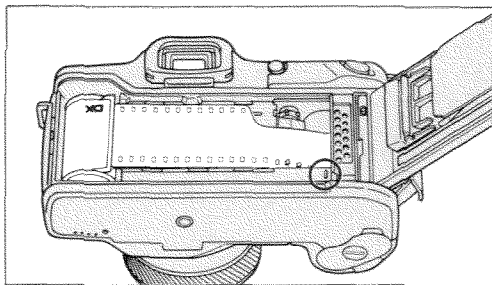

4. Extend the tip of the film past orange mark. Make sure the holes in the lower edge of the film engage the teeth on the sprocket.

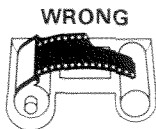
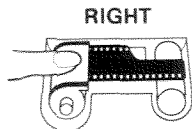

If the film extends too far or does not lie flat, gently push the excess back into the cartridge.

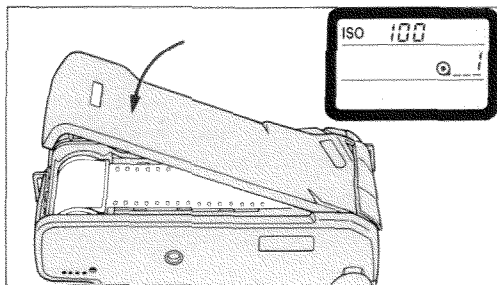

5. Close the back cover so that it snaps shut. The camera will automatically wind the film to the first frame, and 1 will appear in the frame counter.



If the film is incorrectly loaded, the frame counter remains at 0 and blinks, and the shutter locks. Remove the film and repeat steps 3 to 5.

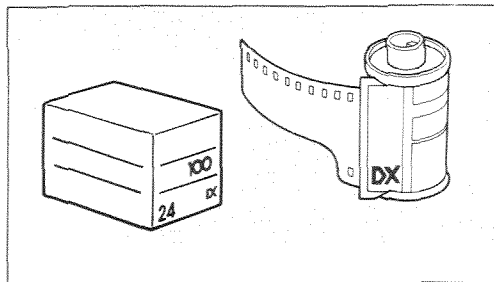

Automatic Film Speed Setting

The film speed is set automatically for ISO 25-5000 DX-coded films. When loading film, be sure to confirm the ISO setting, which will be displayed briefly in the data panel. If the film speed set for a DX-coded film is different than that printed on the film cartridge, the camera's DX-memory is active. Refer to the following page for details on the DX-memory feature.

If you use film that is not DX coded, the previous film speed setting will be retained; initially, this value is set to ISO 100. Instructions for setting the film speed manually are given in the next column.

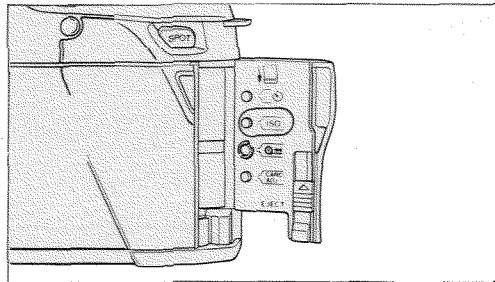

Setting the Film Speed Manually

If desired, you can manually override the DX-coded film speed and reset the film speed to a higher or lower value. Also, if you are using a film that is not DX coded, this control should be used to set the required film speed. Film speeds can be set manually from ISO 25 to 6400, and are selected in 1/3 stop increments.

To Set the film speed manually:

1. Open the card door on the right side of the camera.
2. Press and release the film-speed button. The current film-speed setting will be displayed in the data panel, beside the film-speed mark (ISO).

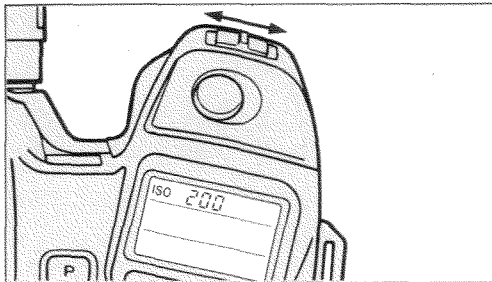

3. Move the setting control right to increase the film speed, or left to decrease it. Holding the control in either direction causes the film speed to change continuously.

4. When the film speed that you want to set appears in the data panel, press the shutter-release button lightly to restore the operating display.

If step 4 is omitted, the film speed currently displayed in the data panel is set, and the operating display returns within 5 seconds.

To confirm the film-speed setting during operation, press the card door's film-speed button: the current setting will be displayed in the data panel for about 5 sec.

DX Memory

Once you change the film speed for a DX-coded film, the adjustment is retained in memory. Until a film with a new DX-coded ISO rating is inserted, the film speed that you have set manually will be automatically applied to all film subsequently loaded. Once a film with a new DX-coded ISO rating is inserted, the film-speed memory will be erased.

The following sequence illustrates DX-memory operation. It assumes that the DX-memory is initially inactive.

Film Operation	ISO Setting
1. DX-coded ISO 100 film loaded	100
2. Film speed manually reset to ISO 50	50
3. DX-coded ISO 100 film loaded	50
4. DX-coded ISO 200 film loaded	200
5. DX-coded ISO 100 film loaded	100

2. BASIC OPERATION

HOLDING THE CAMERA

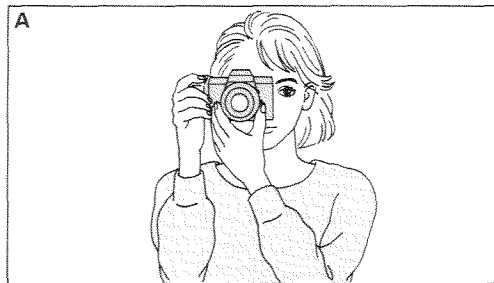

To obtain sharp, blur-free photos, hold the camera as still as possible and steady it against your face or body. To take pictures, press the shutter-release button gently with a slow, steady squeeze— never a quick jab.

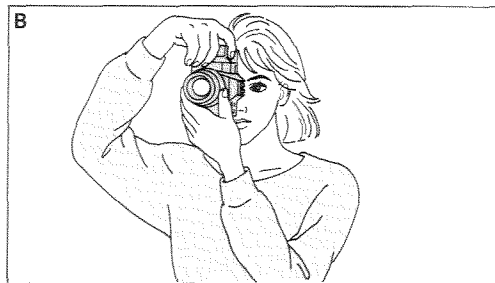

Two recommended ways of holding the camera are shown here. If you grasp the camera firmly with your right hand on its handgrip, you can shift the camera back and forth for horizontal (A) and vertical (B) pictures without removing your hands from the controls. When using auto-focus, make sure not to touch the lens focusing ring or AF illuminator.

SHUTTER-RELEASE BUTTON

In describing camera operation, this manual refers to two shutter-release button operating positions: a pre-release, “partway-down” position that activates the camera’s autofocus and autoexposure systems, and an “all-the-way” down position that triggers the shutter-release sequence. Both operating positions, as well as the rest position, are illustrated at right.

The viewfinder focus and exposure signals function when the shutter-release button is pressed partway down, whether you operate the camera in automatic or manual mode. In manual mode, they can assist you in setting focus and/or exposure.

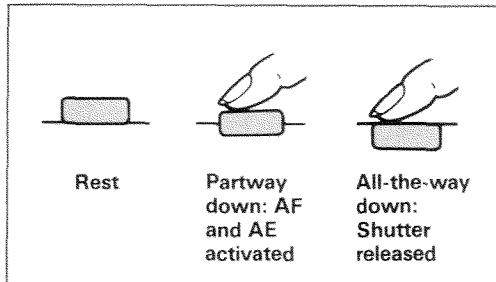

In standard operation, described in the following section, focus and exposure are set when the shutter-release button is pressed partway down; autofocus-integrated metering ensures that exposure is correct for the subject that you focus on.

TAKING A PICTURE

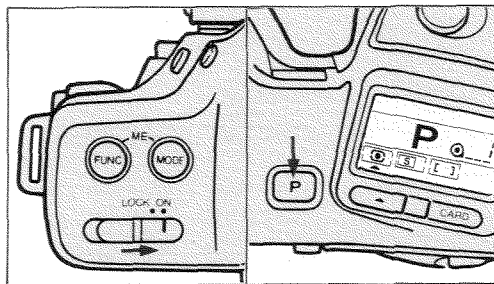

This section describes the simplest way to operate the camera.

1. Slide the main switch to **ON**, then press the program-reset button to set the camera for fully automatic operation.
2. Hold the camera firmly with your right hand on its handgrip and support the lens with your left hand.

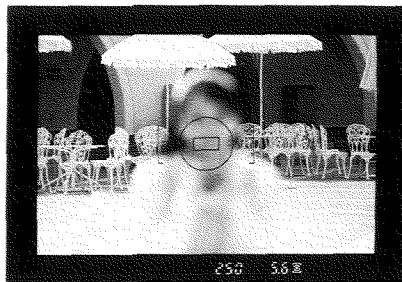

3. While looking through the eyepiece, center the focus frame on your subject and gently press the shutter-release button partway down to focus.



4. When the green focus signal glows, press the shutter-release button all-the-way down to take the picture.

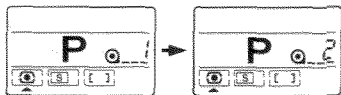

After the picture is taken, the film is automatically advanced and the frame counter increases by one.

If the red rather than the green focus signal blinks, focus the lens manually. Refer to the focusing section for more information.

Program Reset

Pressing the program-reset button brings the camera's main selectable functions to their standard settings, including autofocus and auto-exposure. If you are a first-time user and want to get a feel for the way the camera operates before learning about its functions in detail, this is an easy way to get started. Once you've become familiar with the camera, the program-reset button provides a way to rapidly return the camera to standard operation, useful for when you're through with a setting configuration adopted for a particular shooting situation.

Whenever the program-reset button is pressed, the camera is set to autofocus mode, wide focus area, program exposure mode, multi-pattern metering, single-frame advance mode, ± 0.0 exposure adjustment; also, self-timer and multiple exposure functions will be canceled if previously set.

FILM REWIND

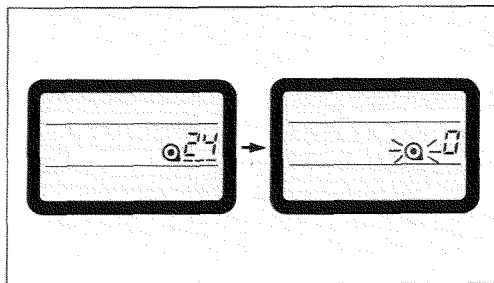

Automatic Film Rewind

After the last frame on the roll is exposed, the camera automatically starts rewinding the film. With a fresh battery loaded in the camera, it normally takes 8 seconds to rewind a 24-exposure film. While rewind is in progress, the frame counter displays the frame number of the last exposure.

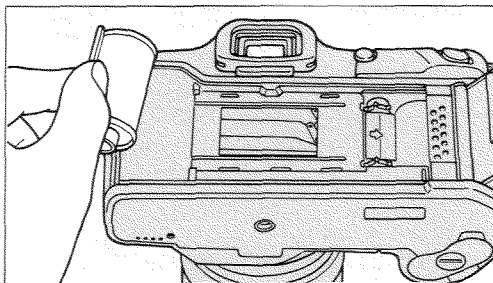

When film rewind is complete, the frame counter displays 0 and the data panel's film-cartridge mark blinks to indicate that the film cartridge can be removed. Open the camera back and remove the film. The shutter remains locked if a re-wound film cartridge is left in the film chamber.

If it's necessary to change batteries before rewind is complete, press the rewind button to restart after the new battery is installed.

The film leader will be wound all the way into the cartridge. If you want the film leader to be left out after the film is rewind, you can use the Customized Function Card to change this function. See p. 64 for more details about this and other Creative Expansion Cards.

If you accidentally open the camera back before the film is rewind, close it immediately. Press the rewind button to finish rewinding the film. Light falling on the film will ruin many of the pictures, but your quick action may save a few.

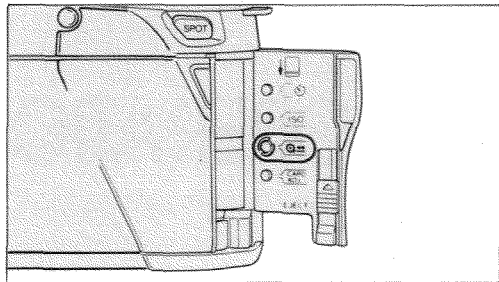

Manual Start of Film Rewind

You can also rewind and remove a roll of film before the last picture is taken. To start film rewind manually, simply open the card door on the right side of the camera and press the rewind (REW) button.

OPERATION IN DETAIL

- Focus
- Exposure
- Metering
- Film Advance
- Exposure Options
- Additional Information

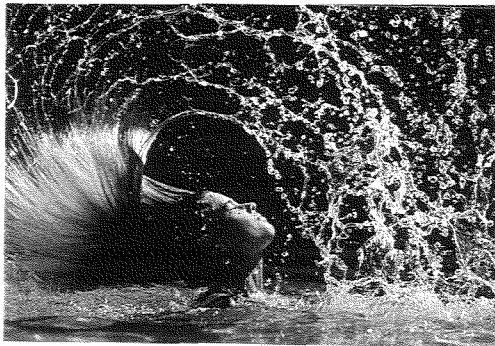

3. FOCUS

BASIC INFORMATION AND MODE SELECTION

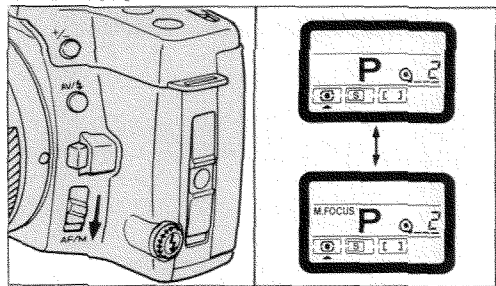

While either autofocus or manual focus can be selected, autofocus is the camera's standard focusing mode, and is set each time the camera is switched on.

To change the focus mode, slide the focus-mode switch *downwards* and then release it; spring action returns the switch to its rest position, and the new focus mode will be set. Whenever manual focus mode is selected, **M.FOCUS** is displayed in the data panel.

AUTOFOCUS (AF)

Operation and Viewfinder Focus Signals

Set to AF mode, the camera focuses automatically when the shutter-release button is pressed partway down. With most subjects, focus is rapidly set: the viewfinder displays a focus confirmation signal and the picture can be taken.

The AF system is capable of focusing on both still and moving subjects. With moving subjects, focus is adjusted continuously according to changes in subject position; in addition, *Predictive Focus Control* improves autofocus operation for moving subjects that are approaching the camera by automatically compensating for the change in subject position that occurs during the shutter-release sequence.

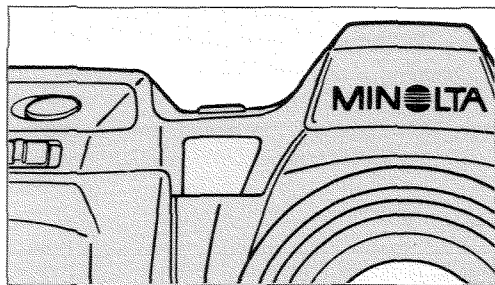

Autofocus itself depends on the detection of subject contrast by the AF system. For low light, low contrast subjects, the camera's AF illuminator is automatically activated when the shutter-release button is pressed partway down; by projecting a beam of red light onto the subject, the AF illuminator, which has a range of 3.3 to 30 ft. (with 50mm lens, based on Minolta's standard test method), provides the contrast needed for autofocus operation.

The AF illuminator does not operate when the lens focal length is equal to or greater than 210mm.

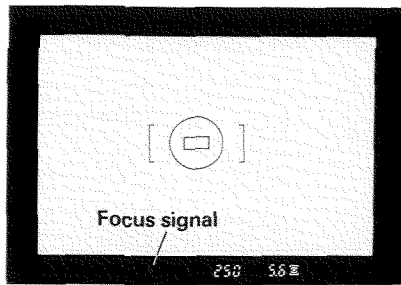

The focus signal displayed in the viewfinder when you press the shutter-release button down depends on whether the subject is still or moving, and on whether or not the camera is able to find focus. When you operate the camera in AF mode, the shutter remains locked if focus cannot be confirmed. Known as focus-priority operation, this design reduces the possibility of your taking an out-of-focus picture.

	Still	Moving
For Confirmed	● (green)	● → ● → ● → ● (green)
Focus Not Confirmed	⊙ (red)	○ → () → () (green)

For low-contrast subjects beyond the AF illuminator's range, the camera may be unable to confirm focus (Fig. A); in these cases, use focus hold (p.26) or focus manually (p.29). The focus-not-confirmed signal for a moving subject will be displayed if its speed is too fast for auto-focusing. Refer to p.28 for more information on subjects difficult to autofocus.

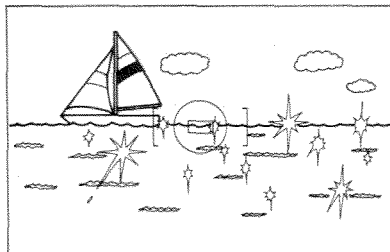

A

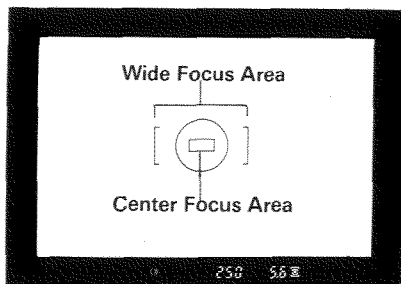

Focus-area selection

The 8000i uses three autofocus sensors for subject detection: a horizontal sensor aligned with the center of the viewfinder frame, and a flanking vertical sensor on each side of the center sensor. When the camera is set to wide focus area (C), all three sensors are used to determine focus. When center focus area (C=) is selected, only the center sensor is used.

Wide Focus Area

Wide focus area is set automatically by the camera when you press the program-reset button. It is convenient for general photographic situations, and especially useful for autofocusing on fast-moving subjects. Even if the main subject is not in the exact center of the frame, the camera will focus correctly.

Center Focus Area

If the camera is set to wide focus area, it may be difficult to focus on one person standing in a crowd, since more than one subject will fill the focus area. By selecting center focus area, you can limit autofocus sensitivity to the small area marked in the center of the viewfinder. Center focus area is also useful for taking closeup photographs.

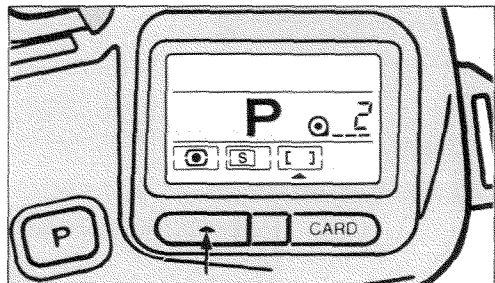

To select the focus area:

1. Press the function-selector key so that the data panel's function pointer is beneath the focus area indicator.

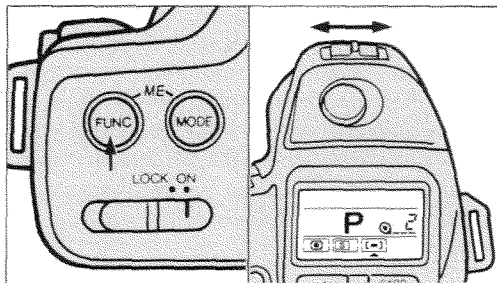

2. While pressing the function-adjustment (**FUNC**) button in, slide the setting control in either direction to select the alternate focus area.

The currently selected focus area is indicated in the data panel.

Focus Hold

Focus hold makes it easy to handle subjects positioned outside the focus frame when you operate the camera in autofocus mode. By temporarily memorizing a set of exposure and focus settings, it allows you to take advantage of autofocus in situations where the main subject is framed off-center, or even at the edge of the frame.

Focus hold can be operated in two ways: with the shutter-release button alone, or by using the shutter-release button in combination with the focus-hold button. The main difference between the two is duration. Using the shutter-release button alone, focus is held for a single exposure only; with the focus-hold button, the AF system is actually disengaged (**M. FOCUS** will be displayed in the data panel) and the current focus setting will be held as long as the focus-hold button is pressed in.

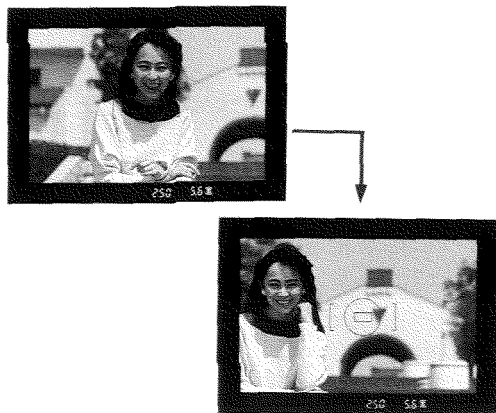

To use focus hold, first center the focus frame on your subject, then press the shutter-release button partway down so that the green focus signal glows. For operation with the shutter-release button alone, simply recompose the picture as desired, making sure that the green focus signal continues to glow, then press the shutter-release button all-the-way down to take the picture.