

# E INSTRUCTION MANUAL

# **DYNAX™** **MAXXUM®** **700si**

PREPARATIONS ■

BASICS ■

FOCUS ■

METERING ■

EXPOSURE ■

FLASH ■

ADDITIONAL ■

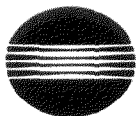

MINOLTA

Welcome to your adventure in photography with the Dynax/Maxxum 700si. This instruction manual will help you understand the 700si's automatic systems and learn how to use its many functions.

The 700si features High-Speed Autofocus, Predictive Focus Control, Minolta's highly acclaimed 14-Segment Honeycomb Pattern Metering, a top shutter speed of 1/8000 second, and Expert Program Selection. As a result, the 700si responds quickly, accurately, and flexibly to virtually any motion, composition, or lighting condition in the moment of a shutter release.

The 700si also offers full control over all camera systems. You can select any of the four local focus areas, take temporary spot readings and lock the spot exposure with the spot button, lock focus with the AF button, and use Memory to save and later recall your most often used camera settings.

First, familiarize yourself with the names of the controls and their location on the camera, then read this manual thoroughly. The Quick Reference Guide in the back of the manual will help you make changes you want when you are in a hurry or simply wish to refresh your memory.

This instruction manual was printed in September, 1993.

## IMPORTANT INFORMATION

The Minolta 700si was designed to work specifically with lenses, flash units, and other accessories manufactured and distributed by Minolta. We therefore caution users of this camera that the attachment and/or use of incompatible products with the 700si may result in unsatisfactory performance or damage to the camera or its accessories. To obtain optimum performance throughout the life of your 700si, we recommend that you use only those lenses, flashes and other accessories distributed by Minolta specifically for use with this camera.

### STATEMENT OF FCC COMPLIANCE

This device complies with Part 15 of the FCC Rules. Operation is subject to the following conditions: (1) This device may not cause harmful interference, and (2) this device must accept any interference received, including interference that may cause undesired operation. Changes or modifications not approved by the party responsible for compliance could void the user's authority to operate the equipment. This equipment has been tested and found to comply with the limits for a Class B digital device, pursuant to Part 15 of the FCC Rules. These limits are designed to provide reasonable protection against harmful interference in a residential installation. This equipment generates, uses and can radiate radio frequency energy and, if not installed and used in accordance with the instructions, may cause harmful interference to radio communications. However, there is no guarantee that interference will not occur in a particular installation. If this equipment does cause harmful interference to radio or television reception, which can be determined by turning the equipment off and on, the user is encouraged to try to correct the interference by one or more of the following measures:

Reorient or relocate the receiving antenna.

Increase the separation between the equipment and receiver.

Connect the equipment into an outlet on a circuit different from that to which the receiver is connected. Consult the dealer or an experienced radio/TV technician for help.

### STATEMENT OF DOC COMPLIANCE

This digital apparatus does not exceed the Class B limits for radio noise emissions from digital apparatus set out in the Radio Interference Regulations of the Canadian Department of Communications.

# TABLE OF CONTENTS

## NAMES OF PARTS

Body . . . . .	4
Body Data Panel . . . . .	7
Viewfinder . . . . .	8

## PREPARATION

Standard Accessories . . . . .	10
Neckstrap . . . . .	10
Eyepiece cup . . . . .	10
Eyepiece and accessory-shoe cap . . . . .	10
Battery . . . . .	11
Installation . . . . .	11
Battery-condition indicators . . . . .	12
Battery performance . . . . .	13
Cold-weather operation . . . . .	13
Lens . . . . .	14
Attaching . . . . .	14
Removing . . . . .	15
Care of glass surfaces . . . . .	15
Film . . . . .	16
Loading . . . . .	16
Manual film speed setting . . . . .	19
Rewinding . . . . .	20
High-speed load and rewind . . . . .	21
Eye-Start . . . . .	22

## THE BASICS

Program-Reset Button . . . . .	24
Holding the Camera . . . . .	25
Looking Through the Viewfinder . . . . .	26

## FOCUS DETAILS

Autofocus . . . . .	30
AF illuminator . . . . .	31
Focus Lock . . . . .	32
Local Focus Area Selection . . . . .	34
Manual Focus . . . . .	35
Special Focusing Situations . . . . .	36

## METERING DETAILS

Honeycomb-Pattern Metering .....	38
Spot Metering .....	40
Center-Weighted Average Metering .....	42

## EXPOSURE DETAILS

P: Programmed Autoexposure .....	44
PA/Ps: Creative Program Control .....	45
A: Aperture-Priority Autoexposure .....	46
S: Shutter-Priority Autoexposure .....	48
M: Manual exposure .....	50
Bulb .....	51
Double Exposure .....	53
Exposure Compensation .....	54
Exposure Bracketing .....	56

## FLASH DETAILS

Built-In Flash .....	58
Red-Eye Reduction .....	59
P-Mode Flash .....	60
Manual fill-flash .....	61
A, S, and M-Mode Flash .....	62
Slow-Shutter Sync .....	63
Flash Compensation .....	64
Remote/Wireless Off-Camera Flash Control .....	65

## ADDITIONAL FEATURES

Metering Index .....	71
Memory .....	72
Self-Timer .....	74
Film Drive .....	75
Depth-of-Field Preview .....	76
Release Priority .....	77
Image-Size Lock .....	78
Panorama Indicator .....	79

## APPENDIX

Accessory Information .....	81
Technical Details .....	85
Caring For Your Camera .....	88
Quick Reference Guide .....	90

## NAMES OF PARTS

For information on specific parts, refer to the page numbers shown in parentheses.

### Body

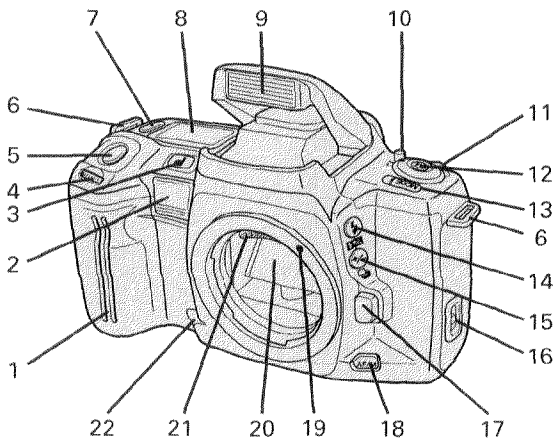

1. Grip sensor (22)
2. AF illuminator/self-timer light (31/74)
3. Program-reset button (24)
4. Front control dial
5. Shutter-release button
6. Strap eyelet (10)
7. Card button
8. Body data panel
9. Built-in flash (58)
10. Memory-switch release (73)
11. Memory switch (73)
12. Memory recall button (73)
13. Exposure-mode button (44-50)
14. Flash-control button (61/64)
15. Exposure-compensation button (54/64)
16. Back-cover release
17. Lens release (15)
18. Focus-mode button (35)
19. Mounting index (14)
20. Mirror\*
21. Lens contacts\*
22. Depth-of-field preview button (76)

\* Do not touch

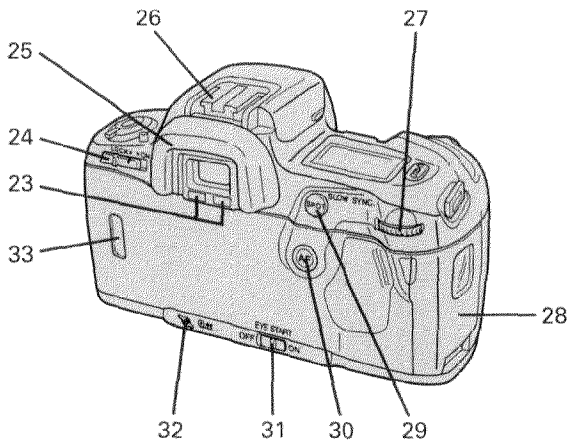

- 23. Eyepiece sensor (22)
- 24. Main switch
- 25. Eyepiece cup (10)
- 26. Accessory shoe
- 27. Rear control dial
- 28. Card door

- 29. Spot button (40,63)
- 30. AF button (32,34)
- 31. Eye-start switch (22)
- 32. Rewind button (20)
- 33. Film window (16)

### Inside Card Door

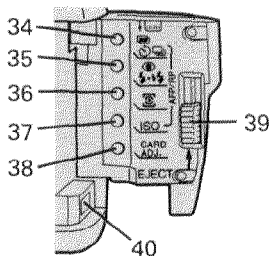

- 34. Self-timer/drive-mode button (53/74/75)
- 35. Flash-mode button (59,60)
- 36. Metering-mode button (38-42)
- 37. ISO button (19)
- 38. Card-adjust button
- 39. Card-eject slide
- 40. Remote-control terminal (52)

## Body

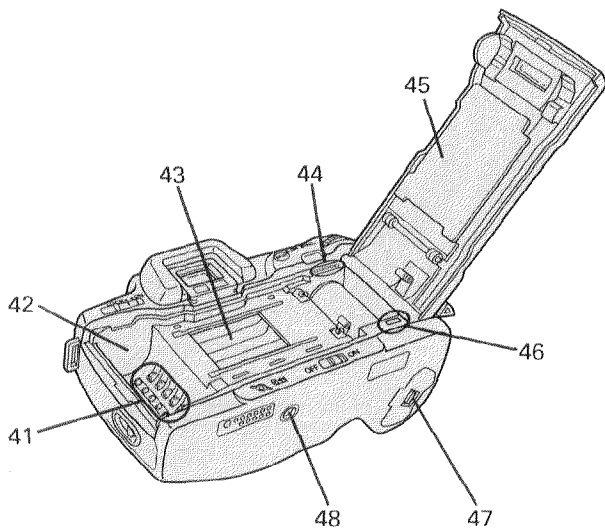

41. DX contacts\*

42. Film chamber (16)

43. Shutter\*

44. Accessory-back contacts\*

45. Pressure plate\*

46. Film-leader index (16)

47. Battery-cover release (11)

48. Tripod socket

\* Do not touch



## Body Data Panel

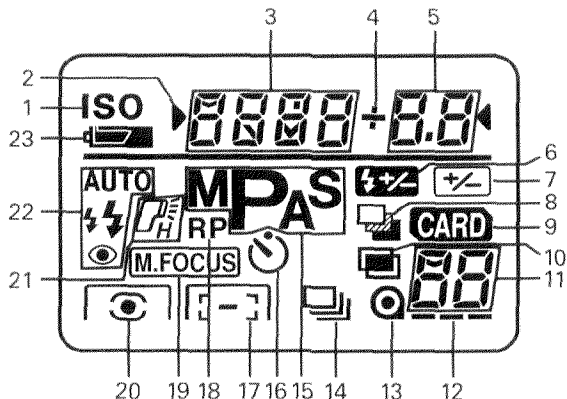

- |  |   |
|--|---|
| 1. Film-speed mark (18,19)   | 10. Double-exposure indicator (54)          |
| 2. Selectable setting pointers   | 11. Frame counter                           |
| 3. Shutter-speed/Film-speed/<br>Card-name/Local-focus-area<br>display                | 12. Film-transport signal (18)              |
| 4. Compensation indicator (54,64)  | 13. Film-cartridge mark (18,20)             |
| 5. Aperture/Exposure-<br>compensation/Flash-<br>compensation/Card-setting<br>display | 14. Drive-mode indicator (75)               |
| 6. Flash-compensation reminder<br>(64)   | 15. Exposure-mode indicators<br>(44-50)     |
| 7. Exposure-compensation<br>reminder (54)  | 16. Self-timer indicator (74)               |
| 8. Exposure-bracketing indicator<br>(56)   | 17. Wide/local-focus indicator<br>(32,34)   |
| 9. Card indicator  | 18. Release-priority indicator (77)         |
|  | 19. Manual-focus indicator (35)             |
|  | 20. Metering-mode indicator<br>(38-42)      |
|  | 21. High-speed sync flash<br>indicator (60) |
|  | 22. Flash-mode indicator (60)               |
|  | 23. Battery-condition indicator (12)        |

## Viewfinder

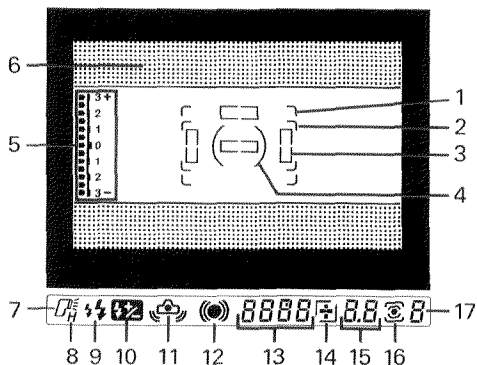

### Viewfinder Screen

1. Horizontal wide-focus frame (30)
2. Vertical wide-focus frame (30)
3. Local-focus areas (32,34)
4. Spot-metering area (40,41)
5. Metering index (71)
6. Panorama indicator (80)

### Viewfinder Data Panel

7. Flash-on indicator (60)
8. High-speed sync flash indicator (60)
9. Flash signals (59,60)
10. Flash-compensation reminder (64)
11. Camera-shake warning (44,47)
12. Focus signals (26)
13. Shutter-speed/Film-speed/Local focus-area display
14. Compensation indicator (54)
15. Aperture/Exposure-compensation/Flash-compensation display
16. Metering-mode indicator (38-42)
17. Frame counter (28)

# PREPARATIONS

## STANDARD ACCESSORIES

### Neckstrap

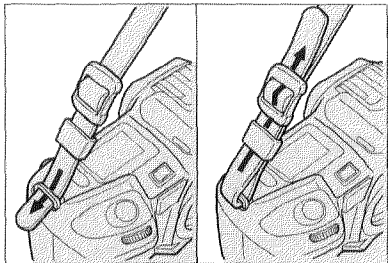

Attach the neckstrap as shown.

### Eyepiece Cup

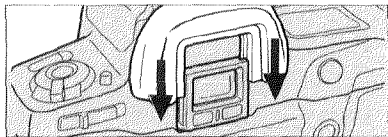

Attach the eyepiece cup as shown.

### Eyepiece and Accessory Shoe Cap

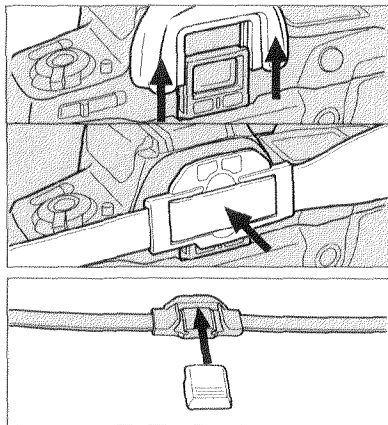

An eyepiece cap is attached to the strap. Before you use the self-timer or make long exposures, remove the eyepiece cup and attach the cap to the viewfinder eyepiece. This will prevent stray light from entering the camera and affecting exposure. The camera also comes with an accessory-shoe cap which protects the accessory-shoe contacts. When you are using a flash or other accessory, slide the accessory-shoe cap into the eyepiece cap for safekeeping.

## BATTERY

This camera uses a 6-volt 2CR5 lithium battery which supplies power for all camera operations. If you are using an xi-Series lens, the camera battery also supplies power to the lens' zoom motor.

### Battery Installation

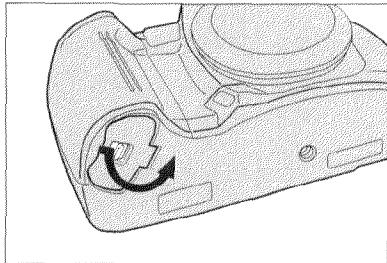

1. Set the main switch to LOCK and slide the battery-cover release in the direction indicated to open the battery cover.

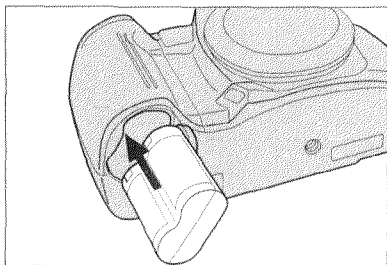

2. Insert the battery according to the marks on the inside of the chamber cover.

3. Snap the cover closed.

### CAUTION

- Read and follow all warnings and instructions supplied by the battery manufacturer.
- Do not attempt to disassemble, recharge, or short-circuit the battery.
- Do not subject it to high temperatures or fire. The battery may explode and cause severe burns.
- Keep batteries away from small children.

## Battery-Condition Indicators

Whenever you slide the main switch from **LOCK** to **ON**, one of the following indicators will appear in the body data panel for 5 seconds.

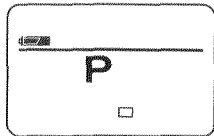

**Power is sufficient** if the full-battery symbol appears.

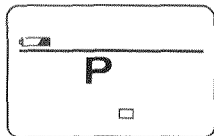

If the low-battery symbol appears, power is sufficient, but getting low. **Keep a fresh battery handy.**

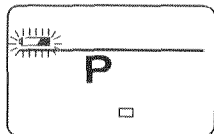

When the low-battery symbol blinks while it appears with other operating indicators at any time during use--camera can be operated, but power is extremely low. **The battery will need to be changed soon.**



If the blinking low-battery symbol appears, or no display appears at all and shutter locks--power is insufficient for operation. **Replace the battery or check that the battery is inserted correctly.**

● This indicator will appear even while the main switch is set to **LOCK**.

## Battery Performance

Flash Use	20°C (68°F)
100%	15 rolls
50%	25 rolls
0%	60 rolls

Based on the following test conditions: 24 exposure roll of film; Eye-Start ON; AF 24-85mm f/3.5-4.5 lens; autofocus from infinity to minimum focus distance and back 3 times; shutter-release button held partway down for 10 seconds before shutter release.

- Battery performance with a 36 exposure roll is reduced by approximately 1/3.
- Because more operations are performed during actual use, battery performance will be slightly lower.
- To maximize battery performance/life, slide the main switch to LOCK when you are not using the camera.

## Cold-Weather Operation

Lithium batteries provide excellent performance in cold weather. However, if you plan to shoot many rolls of film in temperatures near or below 0°C (32°F), we recommend that you carry the camera inside your coat while you are not shooting to keep it warm. You may also want to carry several spare batteries in your pocket so that you can change the camera battery if necessary. Do not discard a cold battery. After it warms up, it will regain some of its charge.

## LENS

### Attaching the Lens

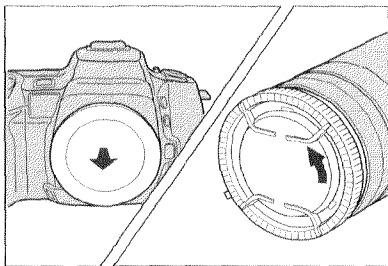

1. Remove the body cap and rear lens cap as shown.

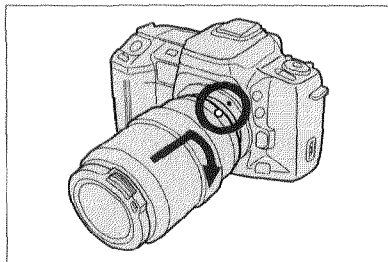

2. Align the red bead on the lens barrel with the red dot on the camera's lens mount. Gently insert the lens into the mount and turn the lens clockwise until it locks in place with a click.

#### CAUTION

- Do not force the lens onto the body if it does not turn smoothly.
  - Never touch anything inside the camera, especially the lens contacts and mirror.
- If “--” appears in the body data panel and viewfinder data panels, lens data is not being transmitted to the camera. This happens when no lens is attached to the camera, the lens is not attached properly, lens contacts are dirty, or a non-compatible lens is attached. When film is loaded, the shutter is locked to prevent accidental exposures. If you want to release shutter under such conditions (eg., when the camera is attached to a telescope), contact your nearest authorized MINOLTA Service Facility.



## Removing the Lens

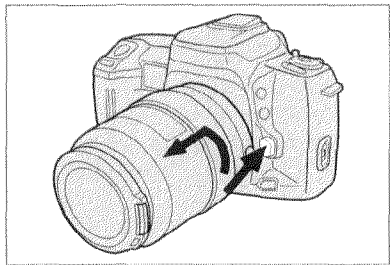

1. While pressing the lens release, turn the lens counterclockwise until it stops. Lift the lens out of the mount.

2. Immediately attach the rear cap to the lens and the body cap or another lens to the camera. This will protect the camera interior, lens contacts, and lens elements.

## Care of Glass Surfaces

- Never touch any lens surfaces (including the eyepiece) with your fingers. If a lens surface becomes dirty, first gently clean it with a lens brush. Then, if necessary, moisten a sheet of lens tissue with one drop of lens-cleaning fluid and, starting from the center of the lens, wipe the glass with a circular motion.
- Never lift the mirror or touch its surface, because this may impair the mirror's alignment or scratch its face. Dust on the mirror will not adversely affect meter readings or picture quality. If it is distracting, have the camera cleaned at an authorized Minolta service facility.

## Loading Film

Before you load film, check the film window. If the film cartridge is loaded, **do not open the back cover**. See page 20 for instructions on rewinding a partially exposed roll of film.

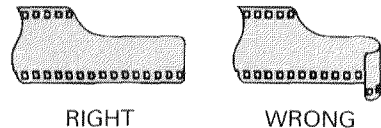
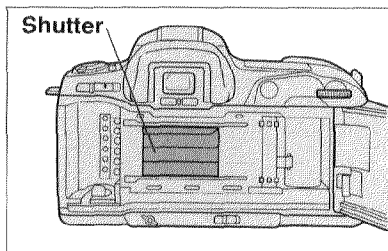
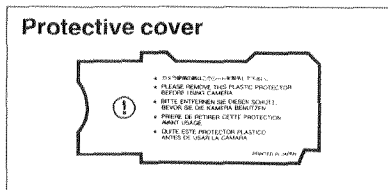

- Before you load film for the first time, remove and discard the protective cover in the film gate.

- Always load film in subdued or shaded light to limit the chances of fogging your film.

- **NEVER TOUCH THE SHUTTER CURTAIN WITH YOUR FINGERS OR WITH THE FILM TIP.** Its precision design makes it extremely sensitive to pressure.

- Make sure the film leader is shaped correctly, otherwise the film may not advance properly. Trim a torn or bent film tip so that it looks like the correct one pictured at left.

- If Eye-Start is on, make sure the main switch is set to LOCK before you begin loading the film; otherwise autofocus may be activated.

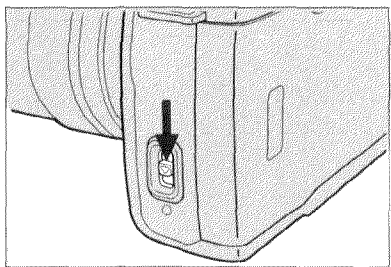

1. Open the back cover by sliding the back-cover release downward.

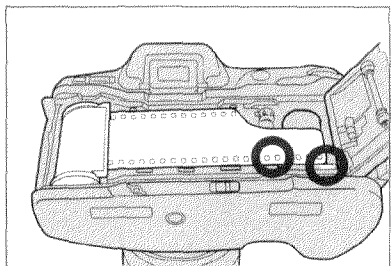

2. Place the film cartridge into the film chamber and extend the leader between the guide rails to the film-leader index. Make sure the sprocket holes in the film's lower edge are engaged by the camera's sprocket teeth.

● If the film tip extends beyond the red mark, gently push the excess film back into the cartridge.

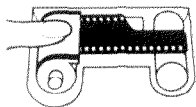

RIGHT

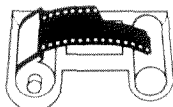

WRONG

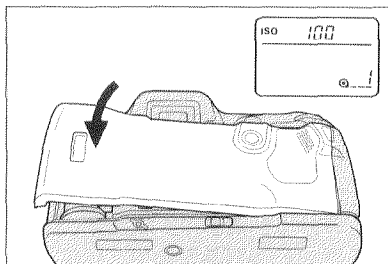

3. Close the back cover and slide the main switch to **ON**. The camera will automatically advance the film to the first frame and **1** will appear in the frame counter.



- If you use DX-coded film, the camera will automatically set the correct film speed and display it in the body data panel for 5 sec. If non-DX-coded film is used, the previous setting will appear.

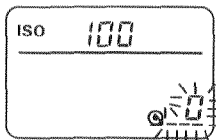

- When the film is loaded incorrectly, **0** will blink in the frame counter and the shutter will remain locked. Open the back cover and repeat steps 2 and 3.

- If you are not using DX-coded film or you want to override the automatically film speed setting, see the Manual Film Speed Setting section on page 19.

- To display the current film speed setting at any time, press the ISO button in the card door--the film speed will appear in the body data panel.

- When you are reaching the end of a roll of film, a frame counter appears in the viewfinder data panel to countdown the last nine frames.

## Manual Film Speed Setting

If you are using a non-DX-coded film or if you want to override the camera's automatic setting, you must manually set the film speed. The camera will initially set non-DX-coded film to the ISO of the previous roll.

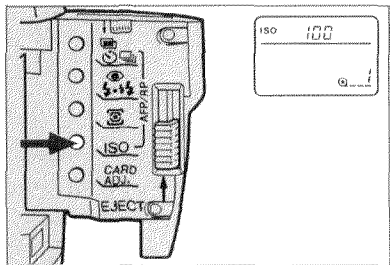

1. Load the film, open the card door and press the ISO button.

2. Turn either control dial until the desired film speed setting appears in the body data panel.

3. Press the shutter-release button partway down to enter your selection.

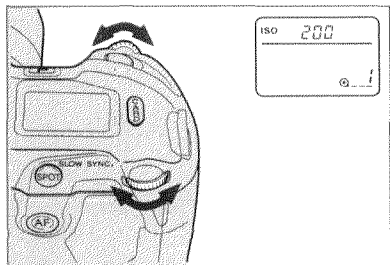

- Each click of the dial will change the film speed setting by 1/3-stop between ISO 6 and 6400.
- For flash exposures, Minolta recommends that you use film between ISO 25 and 1000.

## Rewinding Film

After you have exposed the last frame, the camera will automatically rewind the film silently. With a fresh battery, it takes about 15 seconds to rewind a 24-exposure roll. You can also set the camera so that the film rewinds at high speed (see p.21). It takes about 8 seconds for a 24-exposure roll. When the film has been completely rewound, the motor will stop and the film-cartridge symbol in the body data panel will blink to indicate that it is safe to open the back cover.

### To begin film rewind manually:

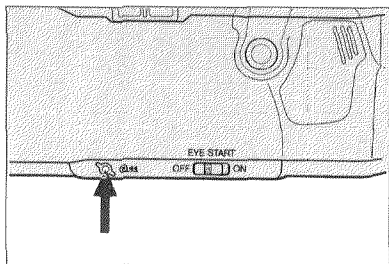

Press the rewind button with your fingernail.

- To finish rewinding the film at high speed, press the rewind button again.

- When the motor stops and the cartridge mark in the body data panel blinks, it is safe to open the back cover.
- If the motor stops before the film is completely rewound, insert a fresh battery. Do not open the back until the film cartridge mark blinks in the body data panel.

## High-Speed Load and Rewind

The camera normally advances the film to first frame and rewinds silently. However, you can select high-speed load and rewind which is approximately twice as fast.

### To select high-speed film load and rewind:

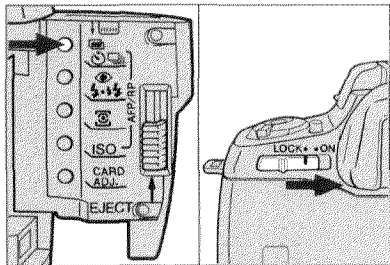

1. Open the card door.
2. While pressing the self-timer/  
drive-mode button, slide the main  
switch from LOCK to ON. "On"  
will appear in the body data panel.

● To return to silent load and rewind, repeat steps 1 and 2 above. "Off" will appear in the body data panel.

## EYE-START

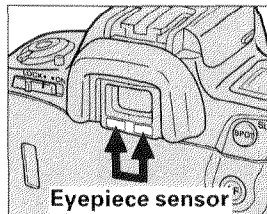
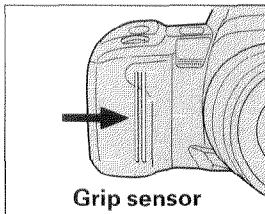
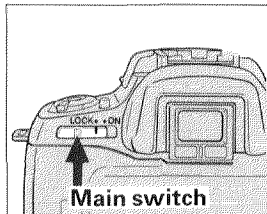

The Eye-Start System automatically activates all of the 700si's main systems as soon as you bring the camera to your eye. When you move the camera's main switch to **ON**, the body data panel and the grip sensor activate. Touching the grip sensor then activates an infrared emitter/detector located beneath the eyepiece. When the eyepiece sensor detects an object near the viewfinder, autofocus and autoexposure immediately activate so that the camera is already operating by the time you frame your main subject.

- When the eyepiece sensor no longer detects an object near the viewfinder, or you break contact with the grip sensor while looking through the viewfinder, autofocus and autoexposure will switch off after five seconds.
- If you are wearing sunglasses which absorb infrared light, Eye-Start may not function.

### To turn off Eye-Start:

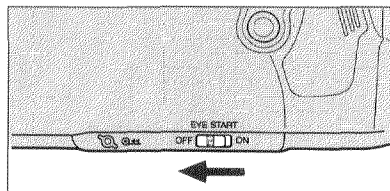

Slide the eye-start switch to OFF.

- To turn Eye-Start on again, slide the eye-start switch to ON.

- When Eye-Start is off, you can activate the camera by pressing the shutter-release partway down.



# THE BASICS

## PROGRAM-RESET BUTTON

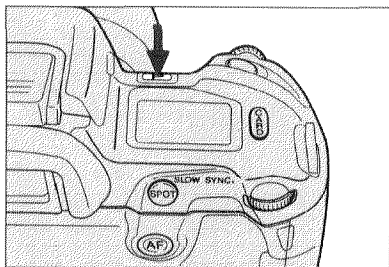

Press the program-reset button to return the following camera functions to their program settings.

Function	Program Setting
Focus area	Wide
Focus mode	Autofocus
Metering mode	14-segment honeycomb-pattern
Exposure mode	P mode
Exposure compensation	+/- 0.0
Built-in flash	Auto on (when up)
Flash compensation	+/- 0.0
Accessory flash (when attached)	Auto on
Film-drive mode	Single-frame advance
Self-timer	Canceled
Shutter-release mode	Autofocus priority

- If you have a dedicated, accessory flash attached to the 700si, pressing the program-reset button will also return it to its own program settings. Refer to the flash instruction manual for details.
- Many of the above settings may be changed with the Customized Function Card xi, available separately.

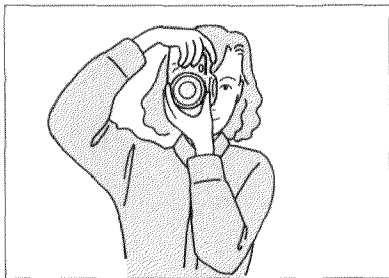

Hold the grip firmly in your right hand and use your left hand to support the camera or lens. Keep your elbows securely against your sides when shooting both horizontal and vertical pictures. When taking a picture, press the shutter-release button gently in a single, steady motion – never with a quick jab. Always keep the camera strap around you neck or wound around one wrist.

- When you pick up the camera, make sure you touch the grip sensor. Otherwise, Eye-start will not function.
- Do not touch the focusing ring of an AF lens or the end of the lens barrel of an xi-Series Autozoom lens.
- Do not block the AF illuminator when you are using autofocus.

The following indicators will appear in the viewfinder while Eye-Start is activated and when the shutter-release button is pressed partway down.

## Focus Area



Horizontal

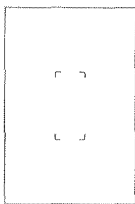

Vertical

This is the camera's wide focusing area as it appears when the camera is held vertically or horizontally. Place your main subject somewhere within this frame.

## Focus Signals



When the blinking ● or (( )) appear, the camera cannot focus on the subject. See Special Focusing Situations (p.36).

- Shutter is locked unless you select release priority (p.77).

(( )) indicates that focus is confirmed in continuous AF.

The focus signal ● appears after you press the shutter-release button partway down indicating that focus is locked. You can take the picture.

- None of the indicators appear while the lens is focusing.

## Exposure Settings



A is the shutter speed the camera is currently using and B is the aperture setting.

## Camera-Shake Warning



When the camera-shake warning blinks, your subject or scene is too dark for a sharp hand-held photograph. Raise the built-in flash or use a tripod. See page 58 for information on using flash.

- This indicator only appears in P and A modes.

## Metering-Mode Indicator



This indicator represents the current metering mode (Honeycomb-Pattern Metering is shown). See Metering Details starting on page 38 for more information.

## Flash Signals



The flash-on indicator blinks when flash is needed (see page 60) and glows when flash will fire with the next shutter release.



The flash signals light when flash is charged. You can take the picture. For more information on flash, see Flash Details starting on page 58.

## Frame Counter



When you are reaching the end of a roll of film, a frame counter appears in the viewfinder data panel to countdown the last nine frames.

- If both the shutter-speed and aperture settings, or metering-mode indicators blink in the viewfinder, see page 44.